

VirTis 35L GPFD 24DX48

General Purpose Freeze Dryer



Key Features

- Compact, freestanding and mobile design.
- Clear acrylic product and condenser chamber doors.
- Optional programmable heat allows for chamber temperature control to 60 °C.
- Intellitronics™ controller with manual and automatic drying capabilities.
- Smooth-wall condenser.
- Stainless steel trays.

Performance Specifications

	ES	XL	EL
Chamber Temperature Control Range (Without Heat)	-29 to 0 °C	-29 to 0 °C	-29 to 0 °C
Chamber Temperature Control Range (With Heat)	-29 to 60 °C	-29 to 60 °C	-29 to 60 °C
Lowest Condenser Temperature (50 Hz / 60 Hz)	-50 °C / -53 °C	-67 °C / -70 °C	-82 °C / -85 °C
Maximum Condenser Capacity	35 L	35 L	35 L
Condenser Surface Area	750 in ² (4838 cm ²)	750 in ² (4838 cm ²)	750 in ² (4838 cm ²)
Maximum Ice Condensing Capacity in 24 hours [†]	20 L	20 L	20 L
Maximum Deposition Rate [†]	0.83 L/hour	0.83 L/hour	0.83 L/hour
Number of Compressors	2	2	3
System Refrigerant (Product Chamber)	R-404A	R-404A	R-404A
System Refrigerant (Condenser)	MO 89	R245fa / R508B	R508B, R407C
Vacuum Time to 100 Millitorr	≤ 30 minutes	≤ 30 minutes	≤ 30 minutes
Vacuum Rate of Rise	≤ 30 mT/hour	≤ 30 mT/hour	≤ 30 mT/hour
Lowest System Vacuum	≤ 30 mT	≤ 15 mT	≤ 15 mT

Note: Performance specifications are based on SP Scientific test data from units operating at an ambient room temperature of approximately 20 °C. SP Scientific recommends an operating range of 15-25 °C (59-77 °F).

Electrical Requirements

	ES	XL	EL
Voltage [*]	208 - 240 VAC	208 - 240 VAC	208 - 240 VAC
Hertz [*]	50 Hz, 60 Hz	50 Hz, 60 Hz	50 Hz, 60 Hz
Phase [*]	1 Φ	1 Φ	1 Φ
Breaker Amperage [*]	20 A	20 A	30 A
Plug Type (60 Hz Systems)	NEMA 6-20-P	NEMA 6-20-P	NEMA L6-30-P
Recommended Receptacle (60 Hz Systems)	NEMA 6-20-R	NEMA 6-20-R	NEMA L6-30-R

Utility Requirements

	ES	XL	EL
Ambient Room Temperature	20 °C	20 °C	20 °C
Approx. Peak Heat Generated (Without Heat)	7,200 BTU/h	7,200 BTU/h	9,800 BTU/h
Approx. Peak Heat Generated (With Heat)	8,900 BTU/h	8,900 BTU/h	11,500 BTU/h

VirTis 35L GPFD 24DX48

General Purpose Freeze Dryer

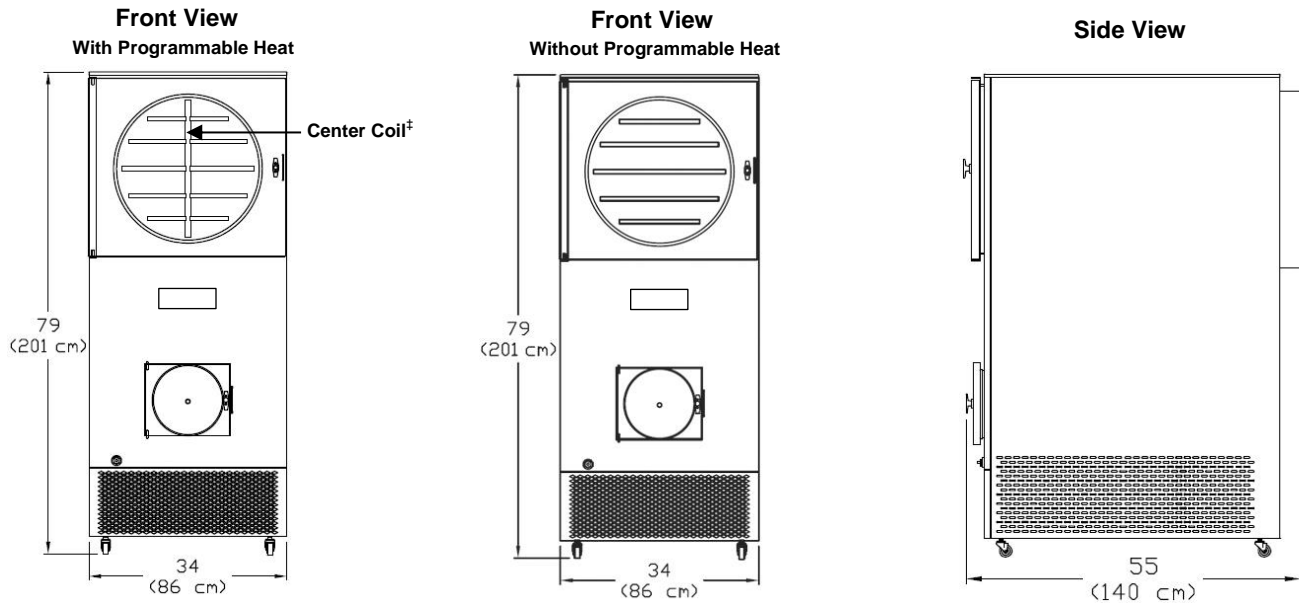

Dimensional Data

Standard Configuration

Width	34 in (86 cm)
Depth	55 in (140 cm)
Height	79 in (201 cm)
Approximate Weight	950 lb (432 kg)
Minimum Clearance on All Sides	10 in (25.4 cm)

Additional Information

Construction	316L Stainless Steel Product and Condenser Chambers
Vacuum Pump	Two-Stage Rotary Vane
Defrost Type	Hot Gas
Refrigerant Type	CFC-Free
Vapor Port	Four (4) Inches

Tray Configuration (Without Programmable Heat)

Tray Levels	Area	Spacing**	Number of Trays
2	13.2 ft ² (1.23 m ²)	7.81 in (198 mm)	4
3	18 ft ² (1.67 m ²)	6.5 in (165 mm)	6
4	23.3 ft ² (2.18 m ²)	5.13 in (130 mm)	8
5	29.8 ft ² (2.78 m ²)	3.85 in (98 mm)	10

Tray Configuration (With Programmable Heat)

Tray Levels	Area	Spacing**	Number of Trays
2	12.3 ft ² (1.15 m ²)	7.81 in (198 mm)	8
3	16.5 ft ² (1.53 m ²)	6.5 in (165 mm)	12
4	21.5 ft ² (2.01 m ²)	5.13 in (130 mm)	16
5	27.5 ft ² (2.57 m ²)	3.85 in (98 mm)	20

* VirTis units are highly customizable and SP Scientific can configure any unit to conform to the service requirements of a wide range of international voltage and phase configurations. Contact SP Scientific for more information.

† The specified Maximum Ice Condensing Capacity in 24 Hours and Maximum Deposition Rate are based on the process of freeze-drying water as aggressively as possible. The freeze dryer's ability to collect ice at an hourly rate or over a specified period is application dependent.

‡ The center coil is provided in the chamber of those units equipped with the programmable heat option. This coil is used to provide uniform heating and cooling of the product chamber and trays. The chamber temperature of units without the heat option is cooled and controlled by refrigeration coils wrapped around the chamber exterior.

** Limited tray spacing available on the top tray.